

MIDLETUBE SYSTEM WITH EXTRA WINDBREAK NET Art. 222 554M



DESCRIPTION

The Middletubesystem closing curtain rolls up from bottom to top with a drive tube in the centre of the net. Because of the central drive tube, the system is more resistant to wind. The advantages of this system are that the net, if desired, can be rolled all the way up and only minimal installation height is required. Because of its simplicity this system is used for natural ventilation for horses, chickens, pigs and dairy cows. An engine installed on a locomotive, that runs vertically along a weighted aluminium rail works the drive.

The system comes with bird netting, fixed to the outside. The bird netting can, if desired due to ventilation needs, be replaced with a net with one or more windbreak factors.

SPECIFICS

Maximum dimensions	Openings up to 110 m wide and 4.5 m high
Opening method	Opens from the bottom upwards
Climate computer	Yes, be aware, local regulations apply
Wind resistance	Up to 100 km/h
Warranty	Yes
Colors	Currently available colors per % on https://agri.vervaeke.be/en/samples

STORM TUBES

Inner storm tubes		
	≤ 4 m height	> 4 m height
Width bay	Tubes/bay*	Tubes/bay*
< 2.50 m	1	1
2.51 m – 3.30 m	1	2
3.31 m – 4.90 m	2	2
4.91 m – 5.50 m	3	3
5.51 m – 6.40 m	3	4
6.41 m – 7.50 m	4	4
Type of storm tube		
	≤ 3 m height	> 3 m height

*Bay = Distance between two columns

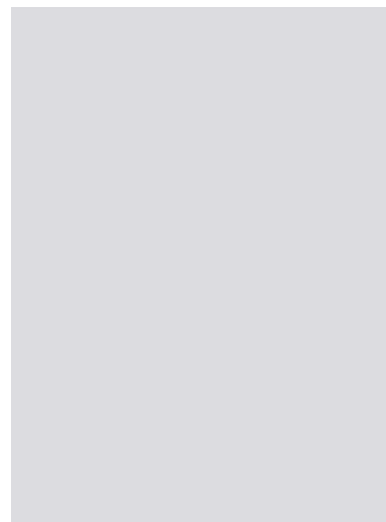

ADVANTAGES



High wind resistance



CE label



Durable



Low maintenance



Custom made

APPLICATION



SPACE REQUIREMENTS

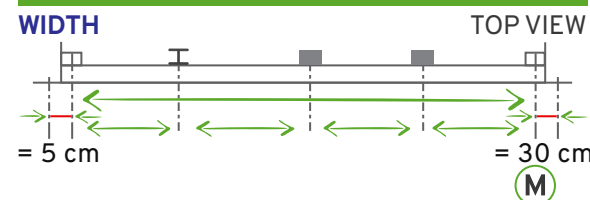
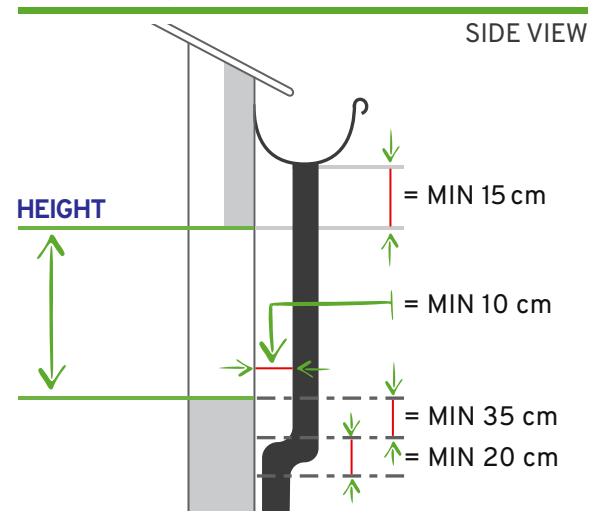

DRIVE M

Huima 5 rpm motor 250 Nm – 3 phase (up to 3 m h)
 Socket 400V 16A +/- 5% at the motor
 Mono: Max. length: 55 m
 Duo: Max. length: 2 x 55 m

Huima 5 rpm motor 500 Nm – 3 phase
 Socket 400V 16A +/- 5% at the motor
 Mono: Max. length: 55 m
 Max. 220 m²/motor
 Duo: Max. length: 2 x 55 m
 Max. 440 m²/motor

EN STANDARDS

EN 13501-1 + A1 : 2009	Flammability	All our curtains have flammability standards. Most have B S2 D0.
		Contact us for the technical datasheet of your fabric.